

KX SERIES

SINE SWITCH

Introduction

Aerospace and defense customers rely on the SENSATA KX Series sealed sine switch when freedom from environmental conditions is required. The versatile KLIXON sine switch element eliminates knife edges and high friction joints. It is sealed within a one-piece steel case with a metal “wave type” diaphragm at the actuating lever engineered to withstand high or low ambient pressures. Typical uses on aircraft include door interlock systems, engine ignition, and thrust reverser indication.



Features

- Hermetic or environmental sealing options provide design freedom for various environmental conditions
- Compactly designed to fit small, narrow spaces
- Snap-acting Klixon sine switch provides exceptional resistance to shock and vibration
- Available with either screw or solder lug type terminals
- Wire leads are available
- Lead lengths can be supplied to customer requirements

Applications

- Door interlock systems on aircraft and industrial equipment/machinery
- Aircraft engine ignitions
- Stowed/deployed indication for thrust reversers
- Aircraft missile launcher position indication
- External stores emergency jettison switches
- Safety ignition indication for military jet engines
- Radar pod door switches
- Tank/armored personnel carrier missile launcher switches
- Tank gun turret position indication

SPECIFICATIONS

Where **KX5** or **KX4** is the temperature rating and type of seal:

Device	Sealed Enclosure Requirement	Maximum Temp.
KX4	Symbol 4 per MIL-PRF-8805 (epoxy sealed)	160° F (71°C)
KX5-1	Symbol 5 per MIL-PRF-8805 (fusion sealed)	275° F (135°C)
KX5-2	Symbol 5 per MIL-PRF-8805 (fusion sealed)	375° F (190°C)

Performance Characteristics

		Resilient Standard Temp.	Hermetic Standard Temp.	Hermetic High Temp.
		KX4	KX5-1	KX5-2
Actuating Force		8 - 24 oz.	8 - 24 oz.	16 - 48 oz.
Release Force		3.0 oz. min.	3.0 oz. min.	3.0 oz. min.
Pretravel		0.025" max.	0.025" max.	0.035" max.
Movement Differential		0.020" max.	0.020" max.	0.024" max.
Overtravel		0.015" min.	0.015" min.	0.015" min.
Positive, Overtravel Stop		Yes	Yes	Yes
Max. Allowable Force on Actuator		25 lbs. Min.	25 lbs. Min.	25 lbs. Min.
Ambient Temperature Range		-65°F to +160°F (-53.8°C to +71.1°C)	-65°F to +275°F (-53.8°C to +135°C)	-65°F to +375°F (-53.8°C to +190.5°C)
Current Rating 28 VDC 110 VAC, 60-400Hz	Resistive	5 Amps		
	Inductive	3 Amps		
	Lamp	2 Amps		
Minimum Life at Rated Load		25,000 cycles	25,000 cycles	25,000 cycles
Vibration Resistance - MIL-STD-202-204 (Test Condition A)		10 G	10 G	10 G
Shock Resistance 1/2 sine wave, 11ms duration		100 G w/o damage	100 G w/o damage	100 G w/o damage
Dielectric Strength		1250 VRMS	1250 VRMS	1250 VRMS
Contact Arrangement		SPDT	SPDT	SPDT
Backfill		n/a	Dry nitrogen	Dry nitrogen
Seal		Enclosure 4, *Resilient	Enclosure 5, **Hermetic	Enclosure 5, **Hermetic
Weight		1.0 oz. max.	1.1 oz. max.	1.2 oz. max.

* Leakage Rate = 1 x 10⁻⁶ cc std atmosphere Helium/second

** Leakage Rate = 1 x 10⁻⁸ cc std atmosphere Helium/second



DIMENSIONS

Revise to read "Dimensions in inches (mm)

Note: Terminal configurations shown below for illustration purposes

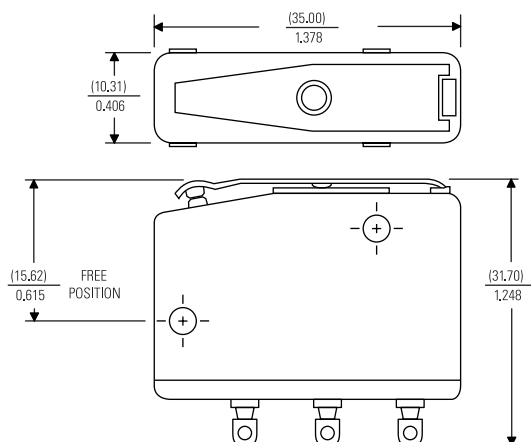

STANDARD TERMINAL CONFIGURATIONS:

Figure A - Epoxy sealed terminals

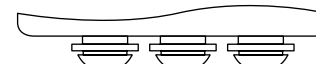
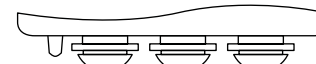

Figure B - Fusion sealed (Glass)



Tin dipped terminals

Figure C - Fusion sealed (Ceramic)



001 SINE SWITCH PACKAGE, 1 POLE (10 amps)

Basic Switch	KX4	KX5-1	KX5-2
Actuating Force (max)	24 oz	24 oz	24 oz
Release Force (max)	3 oz	3 oz	3 oz
Pretravel (max)	.025" (1.02mm)		
Movement Diff (max)	.020" (.76mm)		
Overtravel (min)	.015" (3.18mm)		
Dielectric Strength	1250 VRMS terminal to terminal 1250 VRMS terminal to case		
Approx Weight (no leads)	0.90 oz		

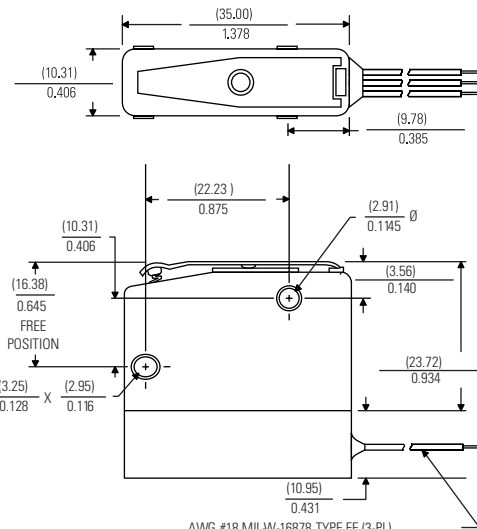

AWG #18 MIL-W-16878, TYPE EE (3-PL)
CODETERMINAL IDENTIFICATION
COM, N.C., N.O.
WITHIN 1" (25.4MM) OF POTTING

NOTE: LEADS SHOWN ABOVE ARE BENT AT 90 DEGREES,
HOWEVER STRAIGHT LEADS ARE ALSO AVAILABLE UPON REQUEST.

002 SIDE PLATE SWITCH PACKAGE, 1 POLE (10 amps)

Basic Switch	KX4	KX5-1	KX5-2
Actuating Force (max)	48 oz	48 oz	48 oz
Release Force (max)	8 oz	8 oz	8 oz
Movement Diff (max)	.090" (2.29mm)		

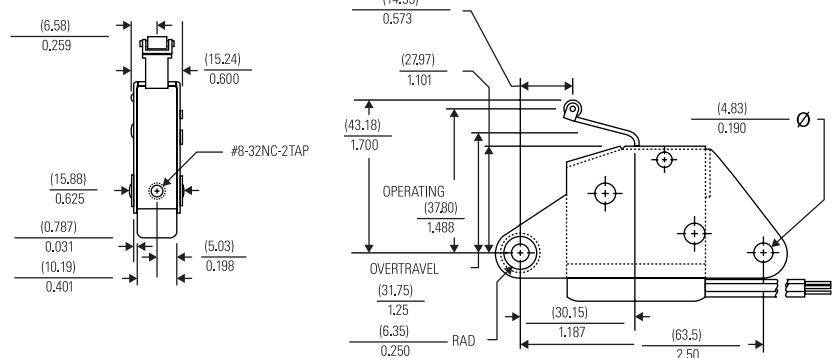

NOTE: LEADS SHOWN ABOVE ARE BENT AT 90 DEGREES,
HOWEVER STRAIGHT LEADS ARE ALSO AVAILABLE UPON REQUEST.

003 SIDE PLATE SWITCH PACKAGE, 2 POLE (10 amps)

Basic Switch	KX4	KX5-1	KX5-2
Actuating Force (max)	96 oz	96 oz	96 oz
Overtravel Force (max)	160 oz	160 oz	160 oz
Pretravel (max)	.100" (2.54mm)		
Movement Diff (max)	.06" (1.53mm)		
Overtravel (min)	.175" (4.45mm)		
Approx Weight (no leads)	12 oz		

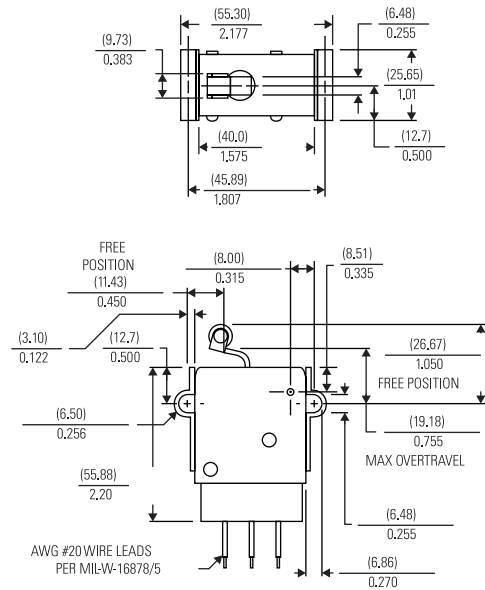

NOTE: LEADS ALSO AVAILABLE WITH 90 DEGREE EXIT UPON
REQUEST.

004 ROLLER LEAF SWITCH PACKAGE, 2 POLE (10 amps)

Basic Switch	KX4	KX5-1	KX5-2
Actuating Force (max)	160 oz	160 oz	160 oz
Release Force (max)	32 oz	32 oz	32 oz
Pretravel (max)	.150" (3.81mm)		
Movement Diff. (max)	.020" (.76mm)		
Overtravel (min)	.450" (11.43mm)		

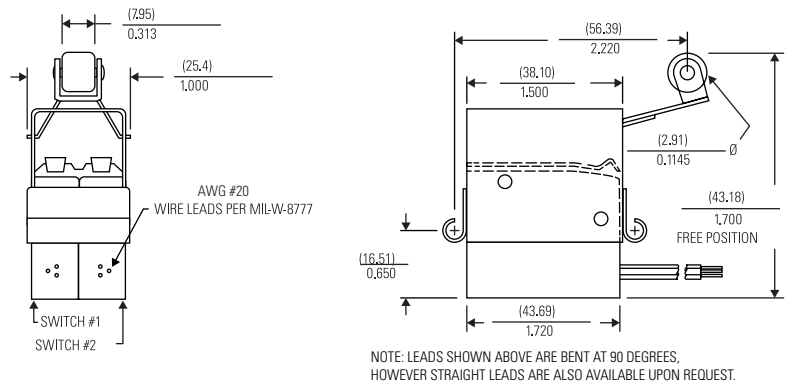

005 PLUNGER SWITCH PACKAGE, 2 POLE (10 amps)

Basic Switch	KX4	KX5-1	KX5-2
Actuating Force (max)	96 oz	96 oz	96 oz
Release Force (max)	32 oz	32 oz	32 oz
Pretravel (max)	.075" (1.91mm)		
Movement Diff. (max)	.030" (.76mm)		
Overtravel (min)	.175" (4.45mm)		
Positive Overtravel Stop	Yes		
Max Force on Actuator	20 lbs		
Approx Weight (no leads)	12 oz		

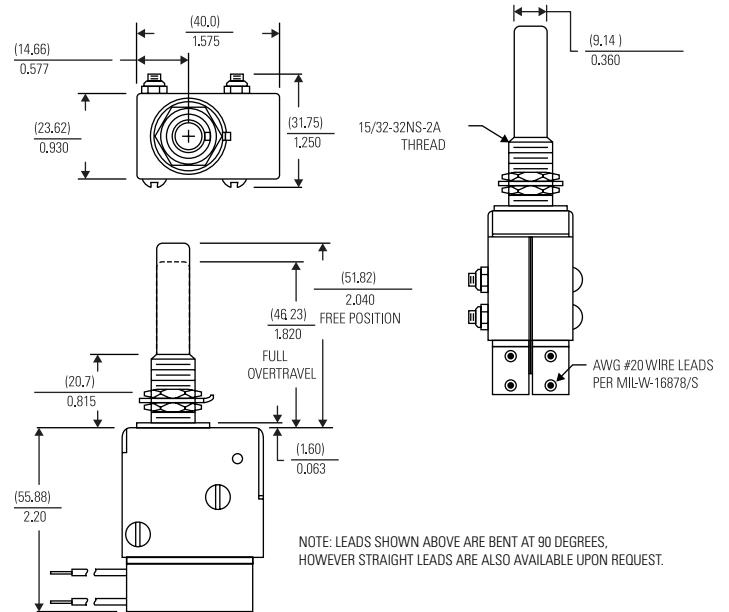

006 LEAF SWITCH PACKAGE, 4 POLE (10 amps)

Basic Switch	KX4	KX5-1	KX5-2
Actuating Force (max)	48 oz	48 oz	48 oz
Release Force (max)	8 oz	8 oz	8 oz
Movement Diff. (max)	.090" (2.29mm)		

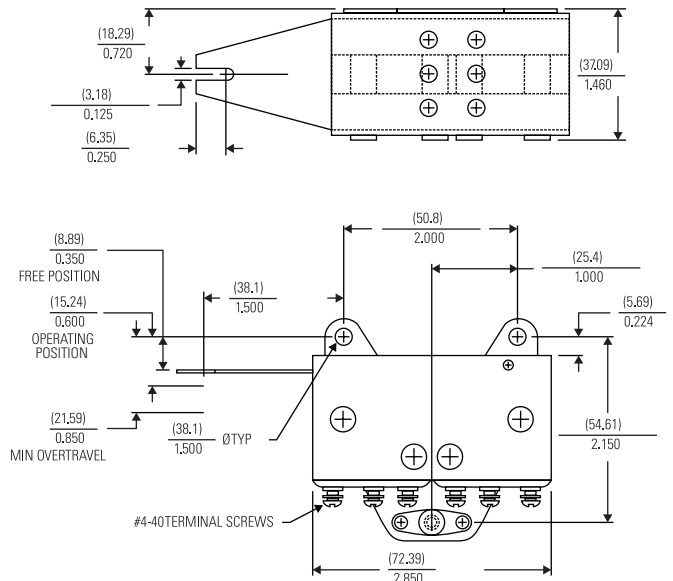

Note: All dimensions are reference only.



WARNINGS



RISK OF MATERIAL DAMAGE AND HOT ENCLOSURE

- The product's side panels may be hot, allow the product to cool before touching
- Follow proper mounting instructions including torque values
- Do not allow liquids or foreign objects to enter this product

Failure to follow these instructions can result in serious injury, or equipment damage.



HAZARD OF ELECTRIC SHOCK, EXPLOSION OR ARC FLASH

- Disconnect all power before installing or working with this equipment
- Verify all connections and replace all covers before turning on power

Failure to follow these instructions will result in death or serious injury.

Sensata Technologies, Inc. ("Sensata") data sheets are solely intended to assist designers ("Buyers") who are developing systems that incorporate Sensata products (also referred to herein as "components"). Buyer understands and agrees that Buyer remains responsible for using its independent analysis, evaluation and judgment in designing Buyer's systems and products. Sensata data sheets have been created using standard laboratory conditions and engineering practices. Sensata has not conducted any testing other than that specifically described in the published documentation for a particular data sheet. Sensata may make corrections, enhancements, improvements and other changes to its data sheets or components without notice.

Buyers are authorized to use Sensata data sheets with the Sensata component(s) identified in each particular data sheet. HOWEVER, NO OTHER LICENSE, EXPRESS OR IMPLIED, BY ESTOPPEL OR OTHERWISE TO ANY OTHER SENSATA INTELLECTUAL PROPERTY RIGHT, AND NO LICENSE TO ANY THIRD PARTY TECHNOLOGY OR INTELLECTUAL PROPERTY RIGHT, IS GRANTED HEREIN. SENSATA DATA SHEETS ARE PROVIDED "AS IS". SENSATA MAKES NO WARRANTIES OR REPRESENTATIONS WITH REGARD TO THE DATA SHEETS OR USE OF THE DATA SHEETS, EXPRESS, IMPLIED OR STATUTORY, INCLUDING ACCURACY OR COMPLETENESS. SENSATA DISCLAIMS ANY WARRANTY OF TITLE AND ANY IMPLIED WARRANTIES OF MERCHANTABILITY, FITNESS FOR A PARTICULAR PURPOSE, QUIET ENJOYMENT, QUIET POSSESSION, AND NON-INFRINGEMENT OF ANY THIRD PARTY INTELLECTUAL PROPERTY RIGHTS WITH REGARD TO SENSATA DATA SHEETS OR USE THEREOF.

All products are sold subject to Sensata's terms and conditions of sale supplied at www.sensata.com SENSATA ASSUMES NO LIABILITY FOR APPLICATIONS ASSISTANCE OR THE DESIGN OF BUYERS' PRODUCTS. BUYER ACKNOWLEDGES AND AGREES THAT IT IS SOLELY RESPONSIBLE FOR COMPLIANCE WITH ALL LEGAL, REGULATORY AND SAFETY-RELATED REQUIREMENTS CONCERNING ITS PRODUCTS, AND ANY USE OF SENSATA COMPONENTS IN ITS APPLICATIONS, NOTWITHSTANDING ANY APPLICATIONS-RELATED INFORMATION OR SUPPORT THAT MAY BE PROVIDED BY SENSATA.

Mailing Address: Sensata Technologies, Inc., 529 Pleasant Street, Attleboro, MA 02703, USA.

CONTACT US

Americas

+1 (508)-236-3287
klixon@sensata.com
 Ask for AEROSPACE